

# Gas Industry Standard

GIS/TE/P6.1:2006

---

Specification for

**Bypass equipment with integral pressure monitoring  
points for MP PE mains**

---





---

## Contents

	Page
Foreword	iii
Mandatory and non-mandatory requirements	iii
Disclaimer	iii
Brief history	iv
1 Scope	5
2 Normative references	5
3 Terms and definitions	5
4 Design requirements	5
5 Performance testing	6
5.1 Pressure testing of system	6
5.2 Functional test of the pressure monitoring system	7
6 Construction and materials	8
7 Handling characteristics	8
8 Marking	9
9 Quality warranty and technical support	9
10 Storage	9
11 Maintenance	9
Figure 1 — Test set up for pressure test of bypass system	10
Figure 2 — Test set up for measuring pressure via the pressure probe	11



## Foreword

Gas Industry Standards (GIS) are revised, when necessary, by the issue of new editions. Users should ensure that they are in possession of the latest edition. Contractors and other users external to Gas Transporters should direct their requests for copies of a GIS to the department or group responsible for the initial issue of their contract documentation.

Comments and queries regarding the technical content of this document should be directed in the first instance to the contract department of the Gas Transporter responsible for the initial issue of their contract documentation.

This standard calls for the use of procedures that may be injurious to health if adequate precautions are not taken. It refers only to technical suitability and does not absolve the user from legal obligations relating to health and safety at any stage.

Compliance with this engineering document does not confer immunity from prosecution for breach of statutory or other legal obligations.

## Mandatory and non-mandatory requirements

For the purposes of a GIS the following auxiliary verbs have the meanings indicated:

- can** indicates a physical possibility;
- may** indicates an option that is not mandatory;
- shall** indicates a GIS requirement;
- should** indicates best practice and is the preferred option. If an alternative method is used then a suitable and sufficient risk assessment needs to be completed to show that the alternative method delivers the same, or better, level of protection.

## Disclaimer

This engineering document is provided for use by Gas Transporters and such of their contractors as are obliged by the terms of their contracts to comply with this engineering document. Where this engineering document is used by any other party, it is the responsibility of that party to ensure that the engineering document is correctly applied.

## Brief history

<p>Edited by BSI in accordance with BS 0-3:1997 Reviewed on behalf of the Gas Distribution Networks' Technical Standard Forum by BSI Reviewed by TSF Reviewed by TSF</p>	<p>August 2006 September 2013  June 2018 April 2023</p>
--	---

© Energy Networks Association on behalf of Cadent Gas Limited, Northern Gas Networks, SGN and Wales & West Utilities Ltd.

This Gas Industry Standard is copyright and must not be reproduced in whole or in part by any means without the approval in writing of Energy Networks Association.

## 1 Scope

This Gas Industry Standard defines the performance requirements of bypass equipment incorporating integral pressure monitoring devices for use on polyethylene systems up to 180 mm diameter operating at 2 bar maximum operating pressures. The maximum length of bypass that can be accommodated using this technology is 12 m.

## 2 Normative references

The following referenced documents are indispensable for the application of this document. For dated references, only the edition cited applies. For undated references, the latest edition of the referenced document (including any amendments) applies.

### Formal standards

BS EN 331, *Manually operated ball valves and closed bottom taper plug valves for gas installations in buildings*.

BS EN ISO 10380, *Pipework — Corrugated metal hoses and hose assemblies*.

### Gas Industry Standards

GIS/PL2-4, *Specification for polyethylene pipes and fittings for natural gas and suitable manufactured gas — Part 4: Fusion fittings with integral heating element(s)*.

## 3 Terms and definitions

For the purposes of this standard the following terms and definitions apply.

### 3.1

#### **pressure probe**

device for monitoring the static pressure at the centre of a gas main

## 4 Design requirements

**4.1** The equipment shall be capable of being attached to a polyethylene pipe by means of a 63 mm electro-fusion branch saddle. The electro-fusion branch saddle shall conform to GIS/PL2-4.

**4.2** The equipment shall be capable of being used on polyethylene mains in the size range 63 mm to 180 mm diameter up to 2 bar operating pressures.

**4.3** The equipment shall be capable of providing a bypass up to 12 m long.

**4.4** The maximum flow rate through the bypass system shall not exceed 300 scmh. Network analysis shall be conducted to ensure that limiting the flow rate to 300 scmh does not compromise the supply of gas to customers.

**4.5** The system shall provide interlocks to ensure that gas main pressure can only be monitored when the pressure probe is fully located within the central section of the gas main being monitored. This is to ensure that only pressure within the gas main is monitored during operations.

**4.6** All moving parts subjected to pressure loading shall be fully retainable within the equipment under all operating conditions and pressures.

**4.7** There shall be a provision for proof testing the equipment to 1.5 times the maximum operating pressure before live gas enters into the bypass system.

**4.8** All valves incorporated into the bypass system shall be approved for use with natural gas and shall have a minimum operating pressure of 2 bar.

NOTE For valves with taper, attention is drawn to the requirements of EC Gas Appliance Directive 90/396/EEC.

Valves with parallel thread shall conform to BS EN 331.

**4.9** All flexible hose systems used in the bypass system shall be approved for use with natural gas and shall have a minimum operating pressure of 2 bar. Flexible hoses shall conform to BS EN ISO 10380.

**4.10** All fabricated components that are not covered by a standard shall be designed to have sufficient strength to withstand all loadings which as a minimum include: pressure, self weight, handling.

**4.11** All components shall be suitable for use with second family gases (natural gas).

## **5 Performance testing**

### **5.1 Pressure testing of system**

#### **5.1.1 Principle**

This test determines the ability of the system to withstand a proof pressure test.

#### **5.1.2 Apparatus**

**5.1.2.1** *63 mm SDR 11 polyethylene pipe, one 6 m length.*

**5.1.2.2** *Two polyethylene pipe end caps.*

**5.1.2.3** *Two 63 mm polyethylene pipe branch saddles.*

**5.1.2.4** *Pressure source, capable of maintaining 3 bar.*

**5.1.2.5** *Pressure gauge, capable of measuring up to 3.2 bar in steps of 0.01 bar.*

#### **5.1.3 Test sample**

A single test set shall be used.

#### **5.1.4 Procedure**

**5.1.4.1** Set up a section of 63 mm polyethylene pipe and attach a pair of 63 mm branch saddles. Cap each end of the polyethylene pipe the branch saddles outlets with electro-fusion fittings (see Figure 1 for spacing of branch saddles).

**5.1.4.2** Proof test the connection of each branch saddles to the main to a pressure of 3 bar for a period of 15 min. Ensure the pressure drop is not more than 25 mbar over this period.



**5.1.4.3** Depressurize the branch saddles and drill through each branch saddle into the polyethylene pipe in accordance with the contractor's instructions.

**5.1.4.4** Set up the equipment to provide a bypass arrangement on the section of 63 mm polyethylene pipe that incorporates the pair of 63 mm branch saddles fused to the polyethylene pipe in accordance with the contractor's instructions. The set-up is to include the pressure probes located in the centre of the main and in the open position. It will be necessary to blank off the open end of the pressure probes. All in-line valves are to be open during this test to ensure the whole system is pressure tested (see Figure 1).

**5.1.4.5** Proof pressure test the whole bypass system and polyethylene pipe to 3 bar and hold for a period of 30 min.

### **5.1.5 Expression of results**

The proof pressure test is deemed acceptable if there is no leakage from system and no failure of any component.

### **5.1.6 Test report**

The test report shall include the following information:

- a) reference to this standard, i.e. GIS/TE/P6.1;
- b) the results of the determination;
- c) any additional factors which may have affected the results of the test.

## **5.2 Functional test of the pressure monitoring system**

### **5.2.1 Principle**

This test determines the ability of the system to monitor the gas pressure only when the monitoring probe is fully located within the polyethylene pipe.

### **5.2.2 Apparatus**

**5.2.2.1** 1 off 6m length of 63mm SDR 11 polyethylene pipe.

**5.2.2.2** 2 off polyethylene pipe end caps.

**5.2.2.3** 2 off 63mm polyethylene pipe branch saddles.

**5.2.2.4** *Pressure source*, capable of maintaining 2 bar.

**5.2.2.5** *Pressure gauge*, capable of measuring up to 2.2 bar in steps of 0.01 bar.

### **5.2.3 Test sample**

A single test set shall be used.

### **5.2.4 Procedure**

**5.2.4.1** Use the test set-up as previously used in **5.1.4.4**.

**5.2.4.2** Set up the equipment to provide a bypass arrangement on the section of 63 mm polyethylene pipe that incorporates the pair of 63 mm branch saddles fused to the polyethylene pipe. The pressure probes are to be in the raised position, and the valve on each branch saddle is to be closed (see Figure 2 for general arrangement).

**5.2.4.3** Attach a pressure transducer to the pressure probe to be tested.

**5.2.4.4** Pressurize the system to 2 bar.

**5.2.4.5** Open one of the valves on the branch saddle and lower the pressure probe into the centre of the polyethylene pipe. Lock the probe in position and check that it registers the full 2 bar pressure.

**5.2.4.6** Raise the pressure probe and close the valve on the branch saddle. Depressurize the pressure probe.

### **5.2.5 Expression of results**

The test is deemed successful if the pressure probe can be inserted and retracted fully into the gas main and it registers the full 2 bar pressure.

### **5.2.6 Test report**

The test report shall include the following information:

- a) reference to this standard, i.e. GIS/TE/P6.1;
- b) the results of the determination;
- c) any additional factors which may have affected the results of the test.

## **6 Construction and materials**

The equipment shall be suitable for use with second family gases. The equipment shall be resistant to oil, MEG and distillate. It shall be lightweight but durable enough for use in operations on the gas supply network by engineering teams and be no more than 21 kg in weight to conform to current manual handling legislation for single person movement.

## **7 Handling characteristics**

**7.1** The equipment shall be designed for good handling characteristics such as the ability for an operative to securely grip the equipment during movement or use.

**7.2** The equipment shall have no sharp edges or other protrusions that can injure hands, fingers, etc. when lowering, lifting or transporting.

## 8 Marking

Products conforming to GIS/TE/P6.1 shall be permanently marked with the following information:

- a) the number and date of this standard, i.e. GIS/TE/P6.1:2006 <sup>1)</sup>;
- b) the name or trademark of the manufacturer or their appointed agent;
- c) the manufacturer's contact details;
- d) the production date, model and serial number
- e) any labels relating to safety, operating and maintenance or servicing instructions
- f) where authorized, the product conformity mark of a third party certification body, e.g. BSI Kitemark.

NOTE Attention is drawn to the advantages of using third party certification of conformance to a standard.

## 9 Quality warranty and technical support

NOTE The manufacturer should have obtained ISO 9001 accreditation and provide technical support and ongoing training on request.

User instructions and initial training shall be provided with each item of equipment.

Full repair facilities and at least 12 months warranty shall be offered.

## 10 Storage

The manufacturer shall have a suitable method of storage supplied with equipment such as, but not limited to, a storage and carrying case.

## 11 Maintenance

**11.1** The equipment shall have access to internal parts only through use of a special tool to help ensure only those persons deemed competent undertake any maintenance activities on the units.

**11.2** The equipment shall provide clear instructions with each unit detailing how any fitted batteries and bulbs or any other component can be exchanged or maintained without invalidating product certification.

---

<sup>1)</sup> Marking GIS/TE/P6.1:2006 on or in relation to a product represents a manufacturer's declaration of conformity, i.e. a claim by or on behalf of the manufacturer that the product meets the requirements of the standard. The accuracy of the claim is therefore solely the responsibility of the person making the claim. Such a declaration is not to be confused with third party certification of conformity, which may also be desirable.

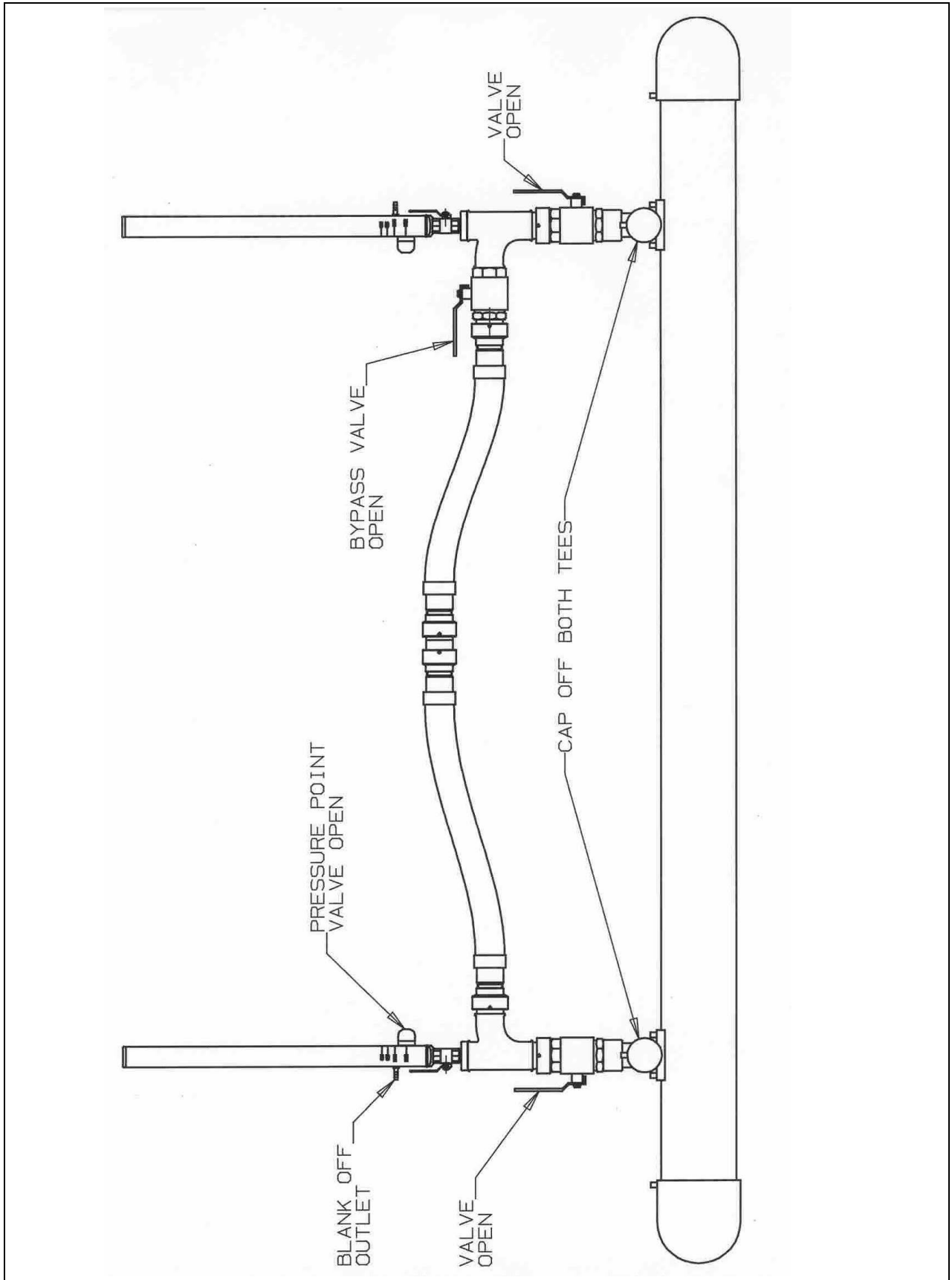
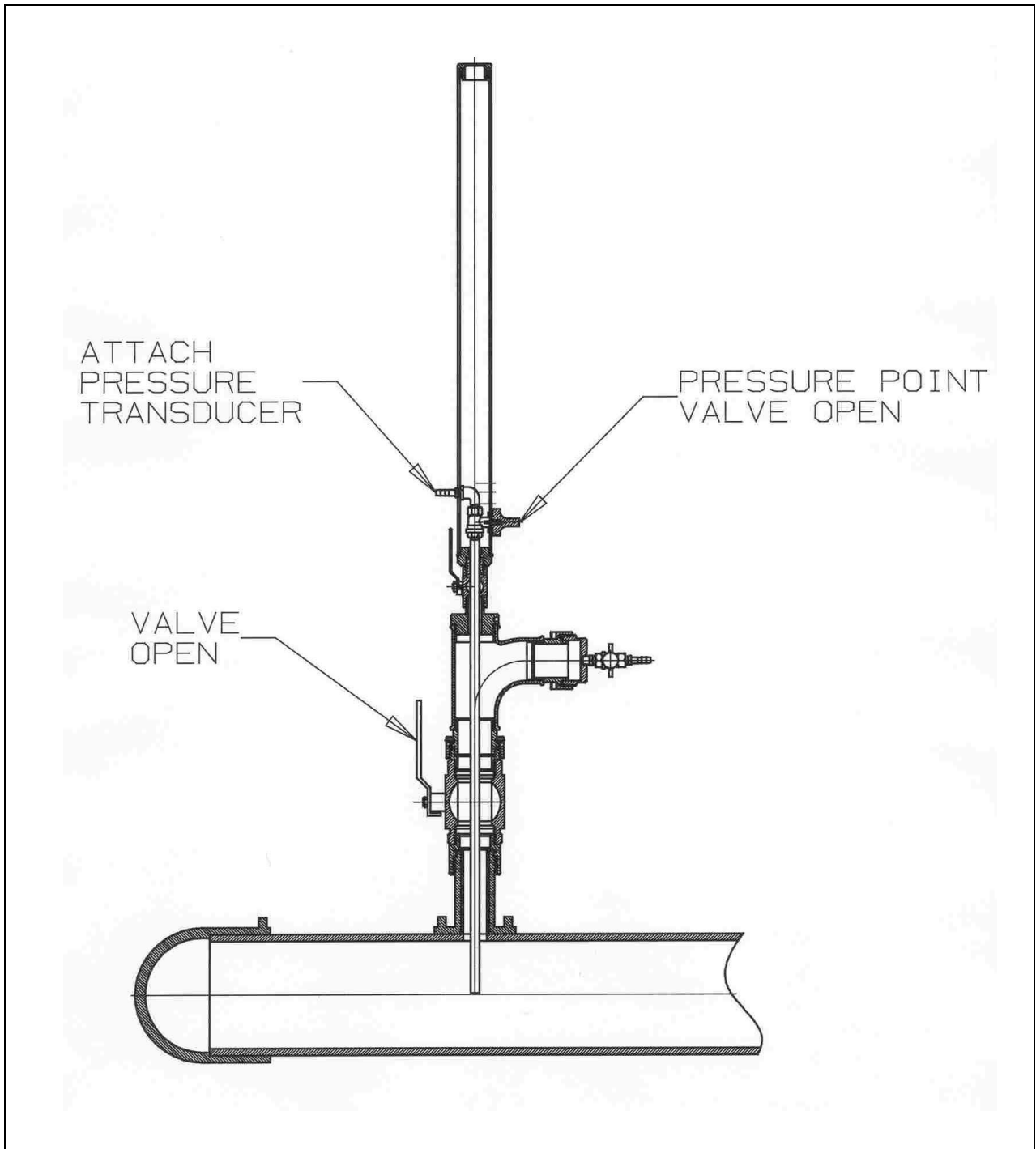

Figure 1 — Test set up for pressure test of bypass system



**Figure 2 — Test set up for measuring pressure via the pressure probe**